

SR Series

Spring Return dosing pump
D - mechanical diaphragm

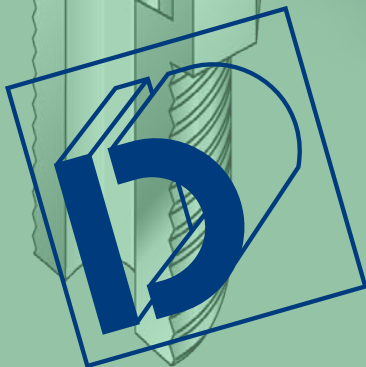
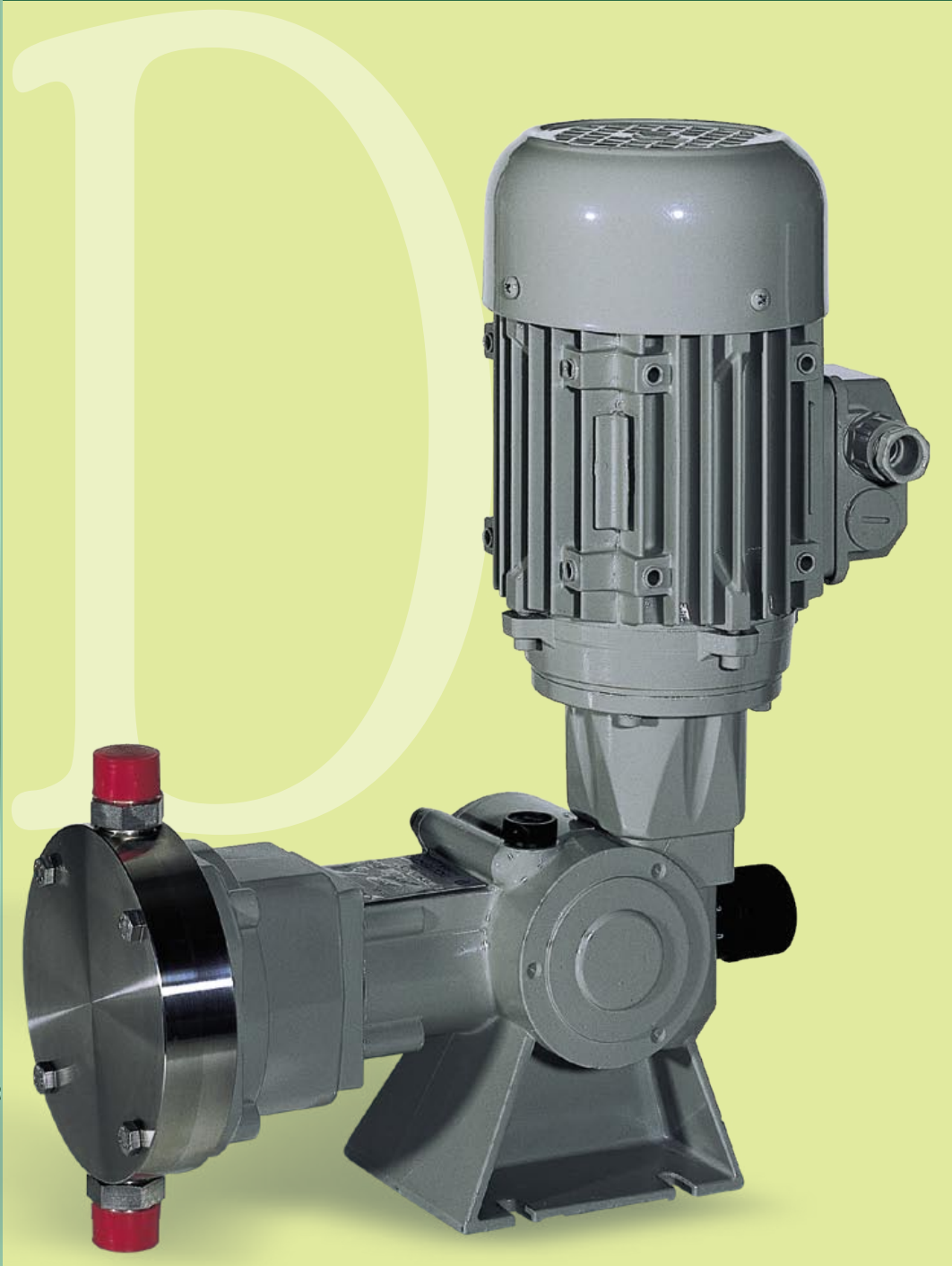
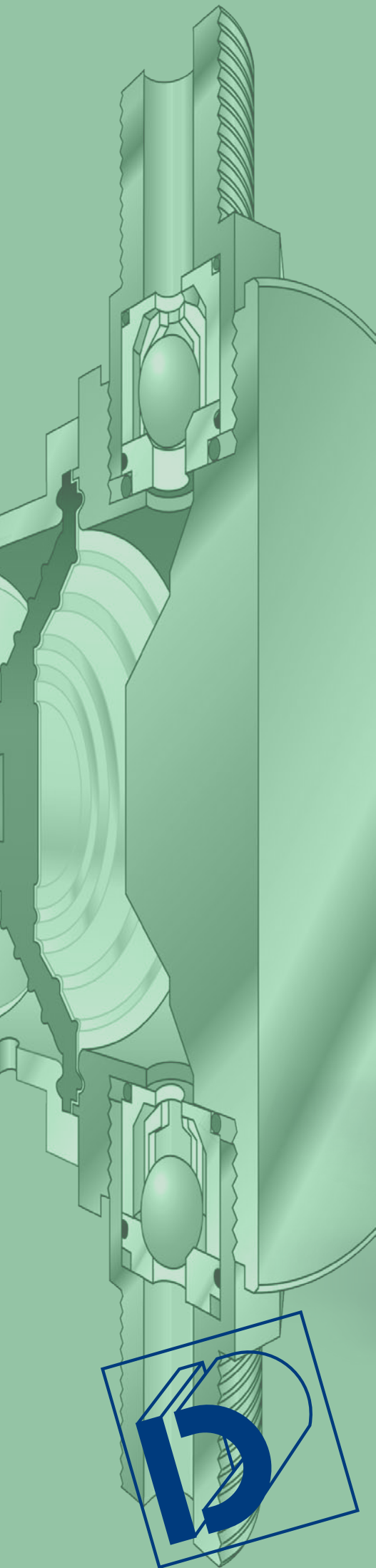

DOSEURO[®]

The right dosing choice



SR Series

Type D

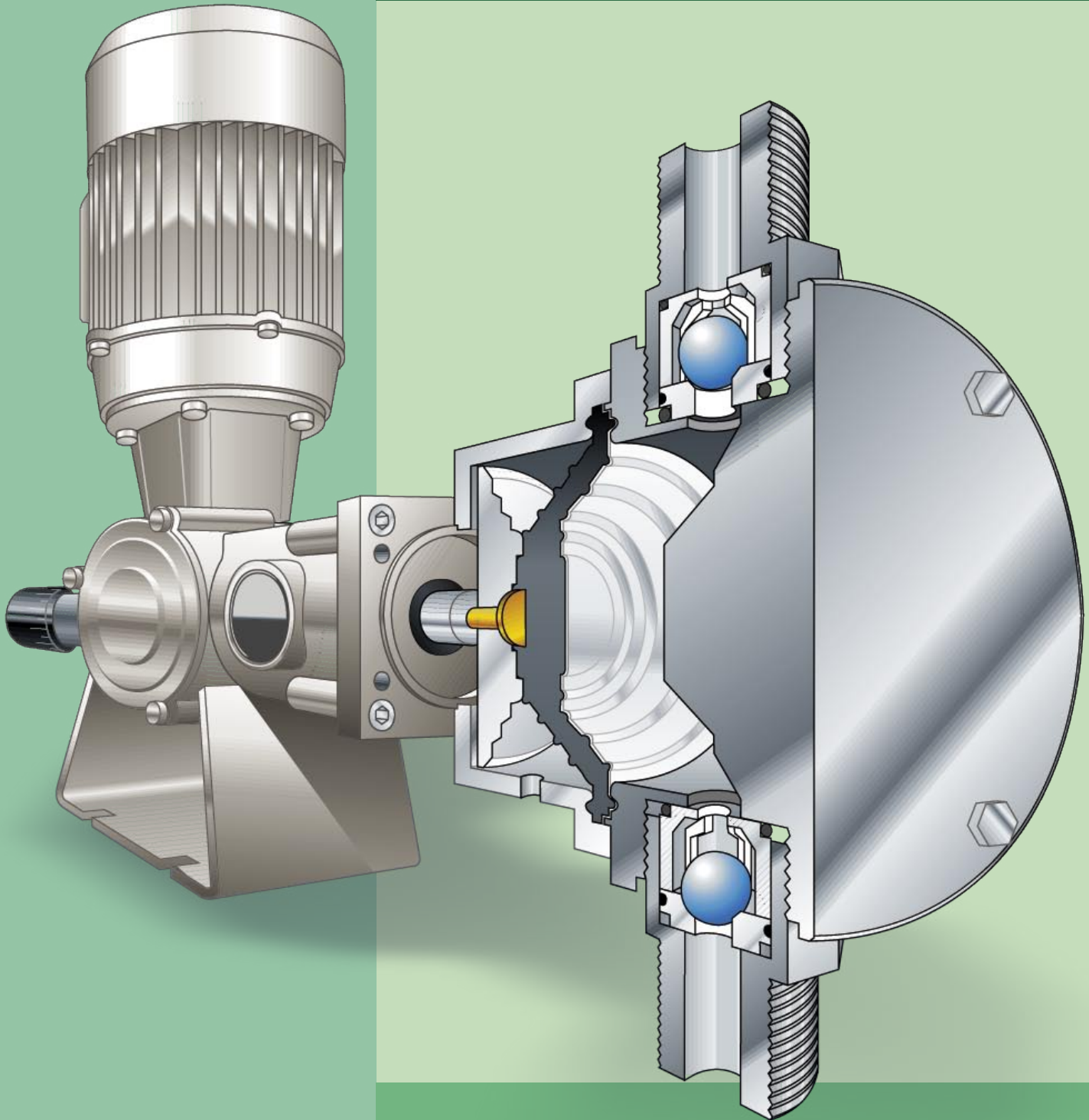



Spring Return Mechanical Diaphragm Dosing Pumps

MAIN ELEMENTS TO SUPPORT OUR PRODUCTS

Versatility

Different diaphragm sizes are available to suit different applications, starting from 4 until 574 l/h

Reliability

The high degree of accuracy and reproducibility with high quality materials selected make the mechanical diaphragm SR series to assure the maximum reliability.

Quality

The best performance for the applications is achieved by optimal selection of material and diaphragm design.

FEATURES

Mechanical Diaphragm pumps are suitable for use when:

- The dosed liquid contains small amounts of suspended solids
- The dosed liquid contains a toxic solution
- A drip proof/air tight application is required
- High pressure is not required

Each pump is fitted a standard gearbox reduction system and with a vertical mounted B14 shaped electric motor in accordance with UNEL-MEC specifications.

The motor power range is from 0.18 Kw up to 0.37 KW as the European standard: 3 phase voltages of 230/400V @ 50/60Hz, 4 pole and 1 phase voltages of 230/50/60 Hz or 110/60 Hz.

As motors conform to UNEL-MEC specifications, there are many alternative option available, including different voltages, insulation class and special explosion proof versions.

The gearbox is a standard wormwheel reduction system with all bearings supported within a fully lubricated gearbox.

The mechanism for variation of the stroke length a positive stroke spring return that is operated by an eccentric.

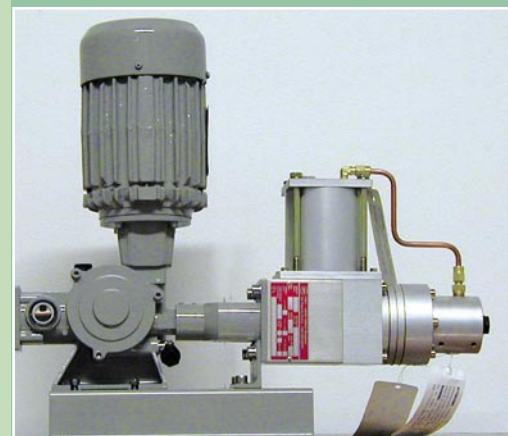
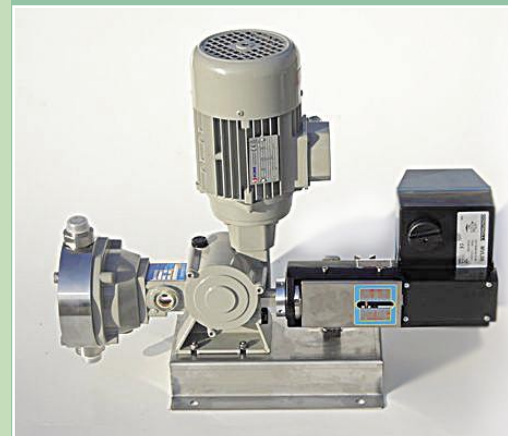



SR Series

Type D

PUMPING HEADS

Pumping heads are made in standard executions: S.S. 316, PVC and PP.

A wide range of other materials like HASTELLOY, ALLOY, PTFE, PVDF are according to the liquid to be dosed. Standard liquid handled maximum temperature

- 60° C with S.S. 316 pump head
- 40° C with PVC pump head

Jacketed pump head for either cooling or heating are available to suit requirements.

DIAPHRAGM

There are made in PTFE / NBR

SUCTION AND DISCHARGE CONNECTIONS

Normally are threaded, but they can be supplied also flanged.

All the pumps have a ball valve standard: single and double balls by the function of the diaphragm diameter or the material execution.

STROKE ADJUSTMENT

Flow rate adjustment is possible while running or at standstill. The movement of the diaphragm is based on a precise reciprocating gearbox, which provides an exact volumetric displacement.

Stroke adjustment can be carried out:

- Manual: by a linear micrometer screw
- Electrical: via servo motor with 4-20 mA signal upon request interface PROFIBUS or other BUS
- Pneumatic: by a pneumatic servo control with signal from 3 to 15 PSI

MULTIPLE HEADED PUMPS

Different multiple heads units are available on request.

Each pumping element has independent adjustment while running or at standstill.

"D" series Mechanical Diaphragm pumps are available in different sizes:

- D 50 N Stroke length 5 mm
- D 100 N Stroke length 10 mm
- D 101 N Stroke length 10 mm
- D 121 N Stroke length 12.50 mm

For these four types, different diaphragm sizes are available to suit different applications for capacity and pressure.

Spring Return Mechanical Diaphragm Dosing Pumps

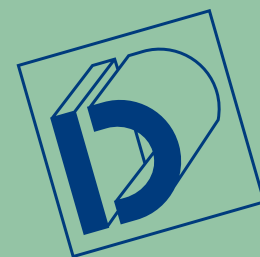

SOME STANDARDS EXECUTIONS FOR MECHANICAL DIAPHRAGM PUMPS

EXECUT.	PUMPHEAD	VALVE (ball)	VALVE SEATS	DIAPHRAGM	VALVES GASKETS
11	S.S. 316	S.S. 316	S.S. 316	PTFE/NBR	FPM
12	PP/FRV	PYREX	PP/FRV	PTFE/NBR	FPM
13	PVC	PYREX	PVC	PTFE/NBR	FPM
16	PVC	S.S. 316	PVC	PTFE/NBR	FPM
17	PP	S.S. 316	PP	PTFE/NBR	FPM
23	PVDF	PYREX	PVDF	PTFE/NBR	FPM

FPM = fluoroelastomer S.S. 316 = stainless steel 316 C.O. = Chromium Oxide PP/FRV = polypropylene + glass fiber
Difference executions on request

Glossary and numbering system to identify pumps type

D	100N	70/	B	11	DV
1ST group	2nd group	3rd group	4th group	5th group	6th group
"D" series Mechanical diaphragm dosing pump	Stroke length	Diaphragm diameter in mm	Reduction ratio group (N° of strokes/min) F(1/24) B (1/12)	Materials in touch with the fluid	Not standard-special code

In case of pumps supplied without motor add: W/M

GENERAL OVERALL DIMENSIONS

	D050	D100	D101	D121
A	57	57	68	68
B	90	90	100	100
C	70	70	65	65
D	75	75	73	73
E	375	375	410	410
F	90	90	90	90
G	75	75	75	75
H	115	115	125	125
I	65	65	65	65
L	7	7	7	7
M	130	130	170	170
N	33	33	33	33
O	80	80	78	78

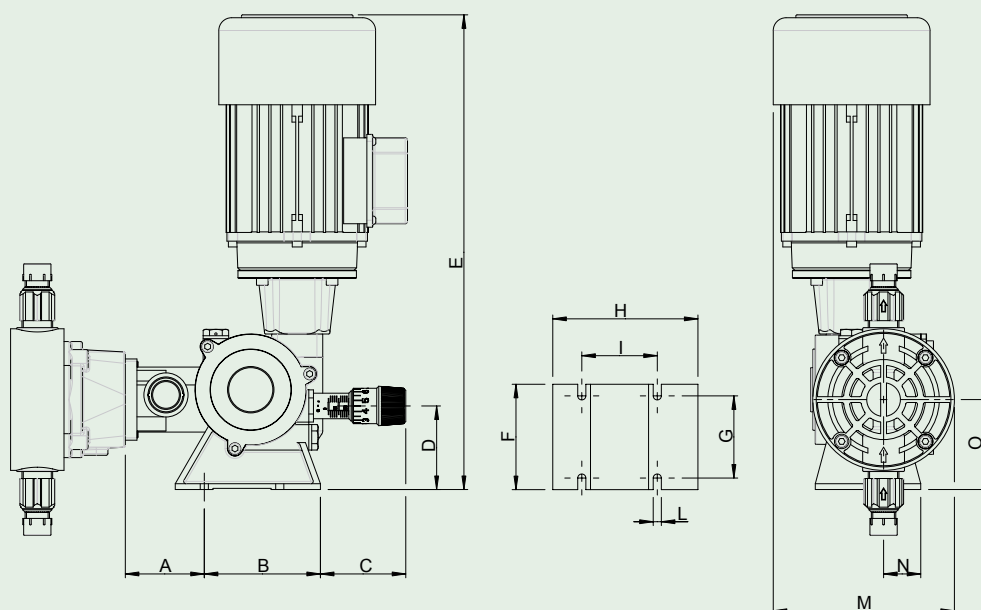

General dimensional quote are indicative and adverted to the maximum acceptable pump dimension



SR Series

Type D 050N



TECHNICAL CHARACTERISTICS

Pump type	Reducer ratio		Capacity (*2)				Max Press. Kg / cm2			Connections (*3)	Motor Features	ø mm Diaphrag.	Stroke Length	Net Weights Kg (*4)		
	(*1)	SPM (*1)		L/1'		Kg/cm2			SS 316+PVC+PP					SS 316	PVC-PP+PV	
		50 Hz	60 Hz	50 Hz	60 Hz	50 Hz	60 Hz	SS 316		PP+PV	PVC					
D-050N-30	I	35	42	0,066	0,08	4	4,8	14	//	10	1/2" G.m.	Kw 0.18 3 Ph ~1400 rpm or Kw 0.18 1 ph ~1400 rpm	30	5	11	8
	F	58	70	0,116	0,140	7	8,4									
	C	96	116	0,191	0,230	11,5	13,8									
	B	116	139	0,233	0,270	14	16,8									
D-050N-50	I	35	42	0,233	0,280	14	16,8	10				50		12		
	F	58	70	0,400	0,480	24	28,8									
	C	96	116	0,683	0,820	41	49,2									
	B	116	139	0,816	0,970	49	58,8									

(*1) Piston's strokes number during 1 minute with 4 poles installed motor (~1400 rpm 1')

I = Reducer ratio 1 : 40 = 35 strokes at 50 Hz / 42 strokes at 60 Hz

F = Reducer ratio 1 : 24 = 58 strokes at 50 Hz / 70 strokes at 60 Hz

C = Reducer ratio 1 : 14,5 = 96 strokes at 50 Hz / 116 strokes at 60 Hz

B = Reducer ratio 1 : 12 = 116 strokes at 50 Hz / 139 strokes at 60 Hz

(*2) The indicated capacity value is subject to change due to the working pressure, dosed liquid, viscosity and installation asset.

(*3) Different ranges of connections are available on request

(*4) The weight is approximate and it is the value of the pump fitted with a totally enclosed fan-cooled outdoor motor.

(5) The pumps can be supplied with accessories if requested

(6) The pumps are epoxy coated RAL 7030

Spring Return Mechanical Diaphragm



Type D 100N



TECHNICAL CHARACTERISTICS

Pump type	Reducer Ratio		Capacity (*2)				Max Press. (*3) Kg/cm2		Connections (*4)		Motor Features	ø mm Diaphrag.	Stroke Length	Net Weights (*5)		
	(*1)	SPM (*1)		L/1'		L/h		SS 316	PVC	SS 316				PVC	SS 316	PVC
		50 Hz	60 Hz	50 Hz	60 Hz	50 Hz	60 Hz									
D-100N-70	I	35	42	0,75	0,9	45	54	5		1/2" G.m.		70		11	8	
	F	58	70	1,25	1,50	75	90									
	C	96	116	2,06	2,50	124	150									
	B	116	139	2,50	3,00	150	180									
D-100N-90	I	35	42	1,15	1,38	69	82,8	3		3/4" G.m.		90		12	8	
	F	58	70	1,91	2,30	115	138									
	C	96	116	3,16	3,83	190	230									
	B	116	139	3,83	4,59	230	276									
D-100N-105	I	35	42	1,56	1,87	94	112,3	1,5		3/4" G.m.		105		12	8.5	
	F	58	70	2,60	3,12	156	187,2									
	C	96	116	4,30	4,96	258	298									
	B	116	139	4,96	5,95	298	357,6									
D-100N-120	I	35	42	1,78	2,12	106	127,4			1" G.m.		120		14	10	
	F	58	70	2,95	3,54	177	212,4									
	C	96	116	4,86	6,23	292	374									
	B	116	139	6,23	7,47	374	448,8									

(*1) Piston's strokes number during 1 minute with 4 poles installed motor (~1400 rpm 1')

I = Reducer ratio 1 : 40 = 35 strokes at 50 Hz / 42 strokes at 60 Hz

F = Reducer ratio 1 : 24 = 58 strokes at 50 Hz / 70 strokes at 60 Hz

C = Reducer ratio 1 : 14,5 = 96 strokes at 50 Hz / 116 strokes at 60 Hz

B = Reducer ratio 1 : 12 = 116 strokes at 50 Hz / 139 strokes at 60 Hz

(*2) The indicated capacity value is subject to change due to the working pressure, dosed liquid, viscosity and installation asset.

(*3) Different ranges of connections are available on request

(*4) The weight is approximate and it is the value of the pump fitted with a totally enclosed fan-cooled outdoor motor.

(5) The pumps can be supplied with accessories if requested

(6) The pumps are epoxy coated RAL 7030



SR Series

Type D 101N and D 121N



TECHNICAL CHARACTERISTICS

Pump type	Reducer Ratio			Capacity (*2)				Max Press. Kg/cm ²		Connections (*3)		Motor Features	ø mm Diaphrag.	Stroke Length	Net Weights Kg (*4)	
	(*1)	SPM (*1)		L/1'		L/h		SS 316	PVC	SS 316	PVC				SS 316	PVC
		50 Hz	60 Hz	50 Hz	60 Hz	50 Hz	60 Hz									
D-101N-70	F	70	84	1,50	1,80	90	108	8		1/2" G.m.		70			11,5	8
	C	96	116	2,05	2,46	123	147,6									
	B	120	144	2,56	3,07	154	184,8									
D-101N-90	F	70	84	2,46	2,96	148	177,6	5		3/4" G.m.		90		13,5	10	
	C	96	116	3,36	4,04	202	242,4									
	B	120	144	4,25	5,10	255	306									
D-101N-105	F	70	84	3,35	4,02	201	241,2	3		1" G.m.		105		14,5	11	
	C	96	116	4,58	5,50	275	330									
	B	120	144	5,51	6,61	331	397,2									
D-101N-120	F	70	84	3,75	4,50	225	270			1" G.m.		120		18	12	
	C	96	116	5,13	6,16	308	369,6									
	B	120	144	6,80	8,16	408	489,6									
D-121N-120	F	70	84	5,36	6,44	322	386,4	3		1" G.m.		120	12,5	18	12	
	C	96	116	7,30	9,56	438	525,6									
	B	120	144	9,56	11,47	574	688,8									

(*1) Piston's strokes number during 1 minute with 4 poles installed motor (~1400 rpm 1')

F = Reducer ratio 1 : 20 = 70 strokes at 50 Hz / 84 strokes at 60 Hz

C = Reducer ratio 1 : 14,5 = 96 strokes at 50 Hz / 116 strokes at 60 Hz

B = Reducer ratio 1 : 11,5 = 120 strokes at 50 Hz / 144 strokes at 60 Hz

(*2) The indicated capacity value is subject to change due to the working pressure, dosed liquid, viscosity and installation asset.

(*3) Different ranges of connections are available on request

(*4) The weight is approximate and it is the value of the pump fitted with a totally enclosed fan-cooled outdoor motor.

(5) The pumps can be supplied with accessories if requested

(6) The pumps are epoxy coated RAL 7030



Spring Return Mechanical Diaphragm Dosing Pumps Accessoriability

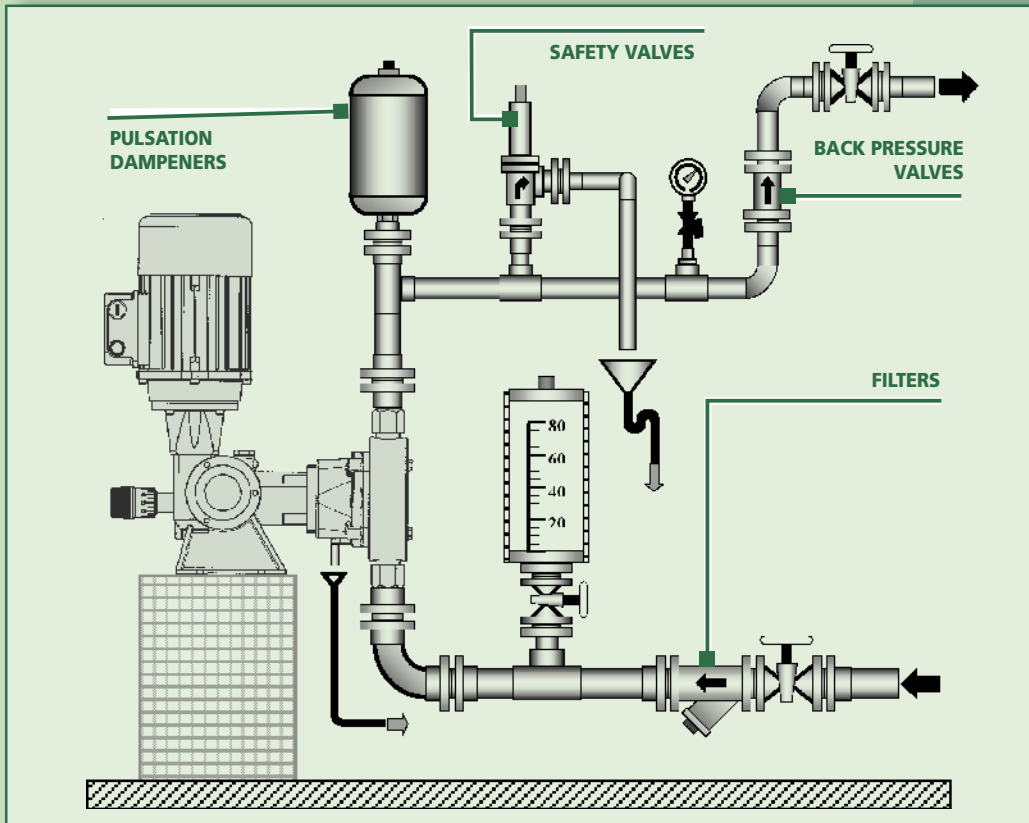

Each metering pump can be supplied with accessories in order to improve the operation and accuracy of the units.

The benefits of fluid control assure

- Increase efficiency and pump life
- Decrease maintenance and operation costs

The control of fluid dynamics is essential to ensure efficient and safe use of process systems. Uncontrolled fluid in motion can physically destroy. A pumping system including the pumping, valves, meters, back pressure valves, inline instrumentation and equipment.

1.- FILTERS

We suggest to install filters (on the suction pipe) to keep back impurities that can be presented on liquid to be dosed or coming from pipeline system.

The use of filters assures a trouble-free dosing.

2.- SAFETY VALVES

Safety valves are designed to protect the pump and chemical feed system from over pressure damage caused by defective equipment or a blockage in the chemical feed line.

3.- BACK PRESSURE VALVES

Back pressure valves apply positive discharge pressure to a metering pump system to prevent siphoning and eliminate varying down-stream pressure.

4.- PULSATION DAMPENER

Metering pumps have a pulsating flow.

Both spring return plunger dosing pumps and quick closing valves start and stop fluids that are in motion. Spring return plunger dosing pumps derive their pumping action by capturing a given amount of fluid in a chamber and pushing it out the pump's discharge.

Each pump cycle includes a suction stroke during the fluid flow is stopped.

This pumping action produces an acceleration/ deceleration of the fluid, creating units of uncontrolled energy, resulting in PULSATION, observed as pressure spikes.

Pulsation dampener is required for two reasons:

- To reduce high, non- permissible pressure fluctuations.
- To create a nearly continuous flow.



Accessories



Safety relief valves

Type	Pump capacity	Connections
TS-10	200 l/h	3/8" or 1/2"
TS-13	400 l/h	1/2" G.F
TS-21	1000 l/h	1" G.F
Body	PVC or S.S. 316	

* S.S. 316 Relief - Safety valve setting pressure: max 40 kg/cm² (588 Psi) higher pressures are available on request.
 PVC Relief safety valve setting pressure: max 10 kg/cm² (145 Psi).
 For higher setting pressures consult our technical dept.



Pulsation dampeners

Type: HSTX

Body in S.S.316, composed of two parts assembled by a special hosing that under dynamic pressures tends to close itself.

Diaphragms are compatible to the liquid used. Built in accordance with ASME VIII° Div. 1 rules.



Type: HSTPVC

Body in PVC, composed of two parts assembled by a special hosing that under hydraulic pressures tends to close itself.

Maximum temperature: + 50 °C.

Diaphragms are compatible with the process liquid.



Relief valves

Type	Pump Capacity	Connections
VSCS-6	90 l/h	1/2" G.F
VSCS-10	230 l/h	1/2" G.F
VSCS-14	420 l/h	3/4" G.F
VSCS-22	1050 l/h	1" G.F
Body	PVC or S.S. 316	
Diaphragm	PTFE/NBR	

* Relief valve setting pressure: 0±20 kg/cm² the max value change due the size and materials
G.F.= Cylindrical, Female



Back pressure valves

Type	Pump Capacity	Connections
VSCC-6	90 l/h	1/2" G.F
VSCC-10	230 l/h	1/2" G.F
VSCC-14	420 l/h	3/4" G.F
VSCC-22	1050 l/h	1" G.F
Body	PVC or S.S. 316	
Diaphragm	PTFE/NBR	

* Back pressure valve setting pressure:
0±2.5 kg/cm²
G.F.= Cylindrical, Female



Polyethylene tanks

suitable to be fitted with metering pump on its top





Our range of production also includes:

SR series:

Hydraulic diaphragm dosing pumps "B", "BR" and "SD" types
Mechanical diaphragm dosing pumps "FM" types
Plunger dosing pumps "A" types

PDP series:

Positive displacement dosing pump "AI" and "SDI" types
High pressure positive displacement dosing pump "AP-AI" types

SDP series:

Solenoid dosing pumps "S" type
Solenoid dosing pumps "GA" type

H series:

Automatic plants for dissolution and preparation of powder polyelectrolytes "HA", "HB" types

EM series:

Electric mixers for chemical mixing "DMT", "DEM", "DRV" and "DRC" types



INTEGRATED DISPENSING SYSTEMS

PO Box 271
Banbury, Oxon, OX16 9FE
Tel.: +44 (0)1295 277731
Fax: +44 (0)1295 277732
e-mail: enquiries@fluidmetering.co.uk
www.fluidmetering.co.uk



DOSEURO®
The right dosing choice