

# INSTRUCTIONS FOR ALL "H" MODEL PUMPS

MODELS RH, RHB, RHSV, RHV, PIP



## LAB PUMP JR.

1000001

CONGRATULATIONS! YOU ARE WORKING WITH ONE OF THE FINEST METERING PUMPS IN THE WORLD - THE FMI LAB PUMP JR., MODEL RH - A RUGGED LITTLE PACKAGE OF EXCEPTIONAL PUMP PERFORMANCE! ITS FLUID PATH IS MADE OF CERAMIC AND FLUOROCARBON TO GIVE

IT OUTSTANDING RESISTANCE TO LABORATORY CHEMICALS; ITS INTERNAL DIMENSIONS ARE MEASURED IN MICROINCHES TO PRODUCE MICROLITER RESULTS. USE IT WISELY AND IT WILL GIVE MANY YEARS OF TROUBLE FREE SERVICE.

## SAFETY INSTRUCTIONS

Before using any Fluid Metering, Inc. product read the following safety instructions as well as specific product specifications and operating instructions.

**Warning! Fire, electrical shock or explosion may occur if used near combustibles, explosive atmosphere, corrosive air, wet environment or submerged in fluid.**

- Turn off the electrical power before checking pump for any problems.
- Connect motor, speed controllers, or any other electrical devices based on Fluid Metering Inc. specifications. Any unauthorized work performed on the product by the purchaser or by third parties can impair product functionality and thereby relieves Fluid Metering, Inc. of all warranty claims or liability for any misuse that will cause damage to product and /or injury to the individual.
- Power cables and leads should not be bent, pulled or inserted by excessive force. Otherwise there is a threat of electrical shock or fire.
- Replace any in-line fuses only with fuse rating as specified by Fluid Metering, Inc.
- When pump/drive is under operation, never point discharge tubing into face or touch any rotating components of pump.
- In a power down thermal overload cut-in condition, unplug or turn off power to pump. Always allow a cool down period before restarting; otherwise, injury or damage may occur.
- For 30 seconds after power is removed from pump/drive: do not touch any output terminals. Electrical shock may occur because of residual voltage.

**Caution! Fire, electrical shock, injury and damage may occur if not used in accordance with Fluid Metering, Inc. specifications and operation instructions.**

- Do not put wet fingers into power outlet of unit.
- Do not operate with wet hands
- Do not operate drive assemblies that require a hard mount (to be bolted down) unless they are mounted per Fluid Metering, Inc. specifications, if not injury may occur and/or damage to unit.
- Do not touch any rotating pump or motor components; injury may occur.
- Do not run pump dry, unless designed for that service. Running dry is harmful to the pump, and will cause excessive heating due to internal friction.
- Check pump rotation and inlet/outlet pump port orientation before connecting power to pump. If not injury may occur.
- When pulling out cords from outlets do not pull cord, grasp plug to prevent plug damage or electrical shock.
- Fluid Metering, Inc. Drive Motors become HOT and can cause a burn. **DO NOT TOUCH!**

### INSTALLATION & OPERATING TIPS

**1. CLEAN FLUIDS.** Abrasives in the pumped fluid may damage cylinder and piston surfaces and should therefore be avoided.

**2. COMPATIBLE FLUIDS.** Pump only fluids compatible with materials of construction of your pump.

**3. WET OPERATION.** The pumped fluid provides surface cooling and lubrication to the piston and cylinder of your FMI PUMP. Therefore avoid dry operation (except pumps specifically designated "gas pump").

**4. PRESSURE.** Do not operate pump against pressures in excess of design specification. Drive pin on piston may bend or break under overload and other irreparable damage may be suffered. Avoid dead heading. **Check your fluid circuit before applying power to the pump!**

**5. CLEANING YOUR PUMP.** Routine flushing with solvent before shut-down will suffice for most applications. Set pump for maximum stroke and operate until solvent appears clear at discharge port.

**CAUTION!** Ceramic piston/cylinder sets are sensitive to neglect and may "freeze if allowed to dry out without adequate cleansing. Fill a loop of flexible tubing with fluid that will thin or neutralize the last fluid pumped. Then connect one end of the tube to the pump suction port, the other to the discharge port. With this loop positioned above the pump head, the ceramic surfaces and seal areas stay moist and mobile for extended idle periods. If, however, a piston does freeze in the cylinder, **DO NOT TRY TO FORCE IT FREE!** Be gentle. Try to remove the pump head (refer to para. 20) from the base assembly so the whole pump head can be soaked in a suitable solvent. If the head is not conveniently removable, the tube loop discussed in the prior paragraph may permit solvent to dissolve the "frozen" residue in reasonable time. If all else fails, pack it all up and ship it back to the factory with a note telling us what you think might be left inside - sometimes we're lucky. New pump heads

are expensive and realigning pump drive components is tedious work, so avoid freeze-ups or, if you feel you must have them, try to correct them gently!

**6. ADAPTING RH PUMP HEADS TO STANDARD Q PUMP DRIVE MODULES.** (refer to figs. 1,7c) The RH/Q Kit adapts the RH pump heads to standard Q Pump Drive Modules. Assemble as follows:

a) Assemble Kit parts to RH pump head as shown (fig. 1) with "shoe" of part H481-1 down. Slip COUPLING H482 fully onto pump shaft, with its slot away from pump head and SET SCREW 110288-4 contacting the flat on the pump shaft.

b) Insert DRIVE PIN 110301 of Kit into SPHERICAL BEARING 110292 as shown.

c) Orientate coupling slot to accept P/N 110301. On Q drives the shoe is slipped between the base Q402 and Q616 assembly.



# FLUID METERING, INC.

5 AERIAL WAY, SUITE 500, SYOSSET, NY 11791

(800) 223-3388 • (516) 922-6050 • FAX (516) 624-8261 • <http://www.fmipump.com>

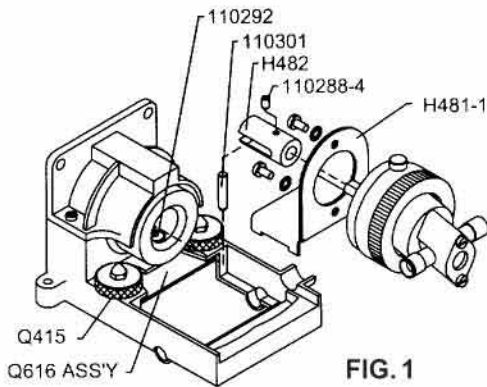

FIG. 1

d) Tighten thumb NUTS and operate motor. If noisy, alter position of BRACKET under RETAINER PLATE slightly while operating until minimal noise position is found. Retighten thumb NUTS.

**7. MOUNTING RH PUMP.** For maximum pump performance, mount RH pump with motor at 12 O'Clock and pump head at 6 O'Clock position. This orientation will allow air bubbles that enter the pumping chamber to directly exit through buoyant assist. Discharge lines should be inclined upward from pump head.

**7.1. PANEL MOUNTING OF RH PUMP HEADS.** Two threaded holes (#8-32) are provided on the back side of each RH pump head for panel mounting purposes. A bearing adjustment access hole is also required. Each panel mount layout should, therefore, provide the three holes as shown in fig. 2. below.

It will be noted that the center line of the pump ports is displaced 90° from the center line of the pump mounting holes. Thus, a

vertical hole pattern in the mounting panel will result in horizontal port alignment of the pump; a horizontal hole pattern will give vertical port alignment.

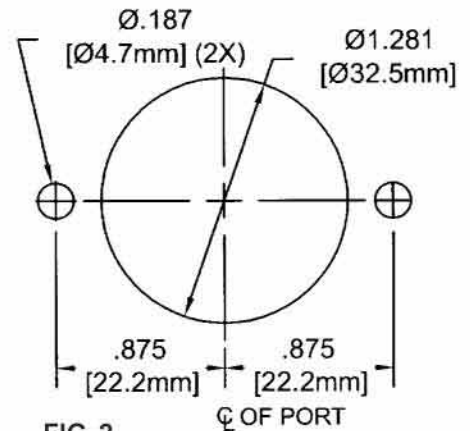

FIG. 2

**RHSY**

**8. RHSY Series pumps** are powered by belt-coupled synchronous motors (refer to figs. 4 & 7c). To service this type of pump, **un-plug power cord**, loosen THUMB SCREW 110437 on rear of CASE ASSEMBLY HSY-109 from COVER ASSEMBLY HSY-113. It will then be noted that a machine SCREW 110230-6 and a STAND-OFF 110439 serve to lock the RH pump head assembly and the SY motor assembly to the COVER ASSEMBLY HSY-113. Removal of the machine screw and stand-off permits removal of pump head and/or motor bracket assembly. Loosening the two machine SCREWS 110132-3 holding the MOTOR ASSEMBLY HSY-110- permits adjustment of the drive belt tension (relocates motor position).

Pulley grooves on motor and pump must be in alignment as shown in fig. 4. SET SCREWS 110288-2 in parts HSY-102 and HSY-105 may be loosened as necessary to achieve such alignment. **Tighten screws** after any service adjustment and **replace CASE ASSEMBLY HSY-109** before plugging electric cord into outlet.

Belt tension should be adjusted to taut condition (no arc in belt between pulleys) but should not excessively stretch the belt. Pump stroke

rate is controlled by the groove position in which the belt has been placed. Thus in fig. 4, with belt in central position as shown, the pump operates at 300 strokes per minute; with belt on the small-motor-pulley and large-pump-pulley, (fig. 4) it operates at 150 strokes per minute and with the belt on the large-motor-pulley/small-pump-pulley the pump operates at 600 strokes per minute.

**"PiP" micro π-petter®**

**9. The FMI micro π-petter® "PiP"** has three switches to control its functions: 1) A PENDANT (squeeze button) switch at the end of a 6' long remote operating cord. This switch starts and stops each operating cycle. It is sealed and can be actuated by hand, foot or other remote pressure means. 2) A "MODE" switch face-mounted on the PiP. In the down or SINGLES position this switch permits only one dispense or aspirate pulse per squeeze of the PENDANT and the up or REPEAT position permits the PiP to operate continuously as a pump, when pendant is squeezed operation is temporarily disabled. A center OFF position on this switch provides system-off facility. 3) A DIRECTION switch controls and indicates the direction of fluid flow through the PiP pump head. Pushing the direction switch to the FWD or up position will cause flow in that direction. Push switch down to the REV position to reverse flow direction.

may have smaller inside diameter than suction tube and may incorporate dispense tip or other partial flow restrictors.

**11. BUBBLE-CLEARING.** After tubing has been securely installed in each of the pump head fittings and the suction line is in the supply fluid, plug electric cord into outlet and operate pump in forward mode until apparent bubbles are cleared from fluid lines. Then, while pump is still operating, pinch-close the suction line for 10 to 15 seconds to cavitate residual bubbles from pump head. Continue to operate until all bubbles are cleared from discharge tube.

**12. PUMP STROKE ADJUSTMENT.** The knurled ADJUSTMENT NUT on the pump head controls stroke to stroke piston displacement. Turning it clockwise to zero stops displacement. Turning the ADJUSTMENT NUT counterclockwise four and one half turns from zero (450 on scale) (fig. 5) causes maximum pump reciprocation, e.g., 50 µl per stroke for the H-0 or 100 µl for the H-1 unit. Thus each 1-1/8 turn (112.5 on scale) of the ADJUSTMENT NUT represents 25 of maximum (12.5 µl for H-0 and 25 µl for H-1) and each graduation on the ring represents an adjustment of 1/450th of maximum (0.111 µl for H-0, 0.222 µl for H-1).

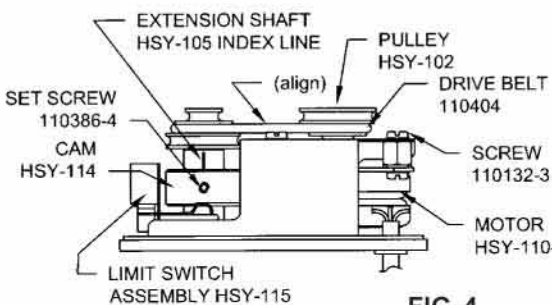

FIG. 4

**RH PUMP HEAD CALIBRATION**

**10. HOOK-UP.** The pump ports of the FMI RH Pump Head are designed to accept 1/4" outside diameter (O.D.) tubing and/or tubing adapters. (see fig. 7a) The lower port is normally for suction, the upper port for discharge. Suction tubing should be soft and flexible with largest possible inside diameter, shortest practical length. Discharge tube

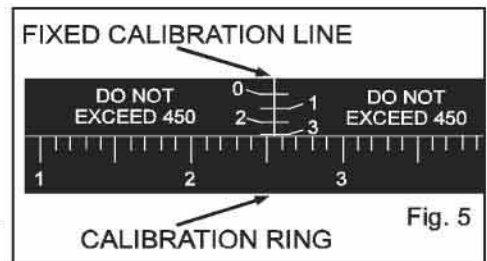

Fig. 5

# FMI LAB PUMPS, MODEL RH, RHB, RHSY, RHV



## PARTS IDENTIFICATION SHEET H431-02

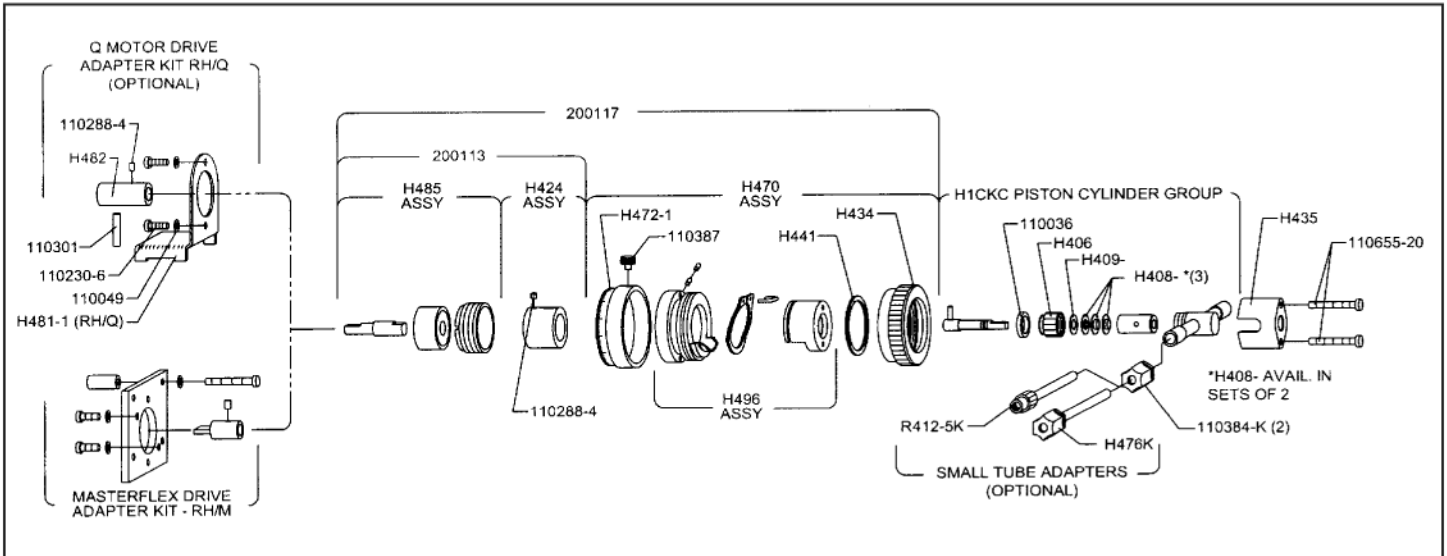
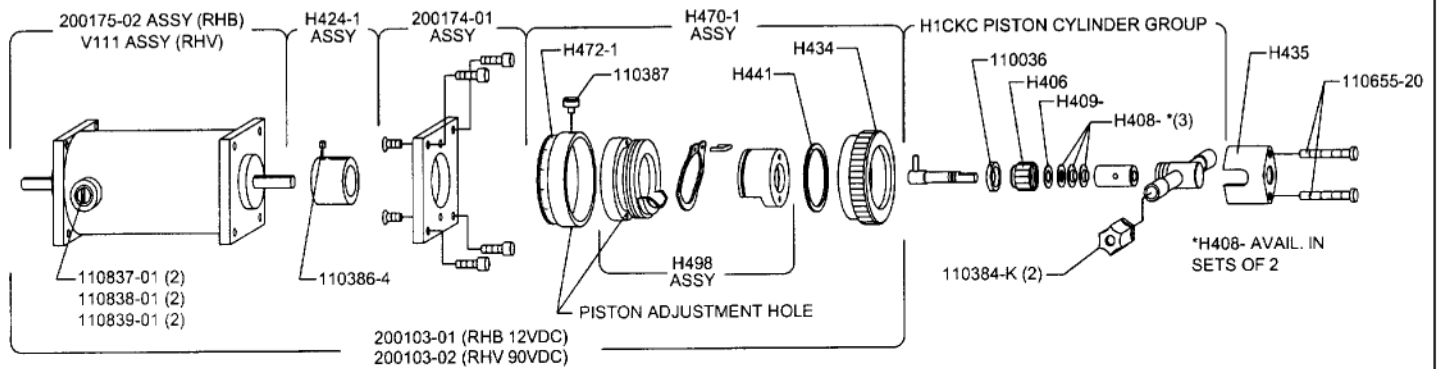

FIG7c

MODELS RH00CKC, RH0CKC, RH1CKC

FIG.7a



MODELS RHB00CKC, RHB0CKC AND RHV1CKC

FIG.7b

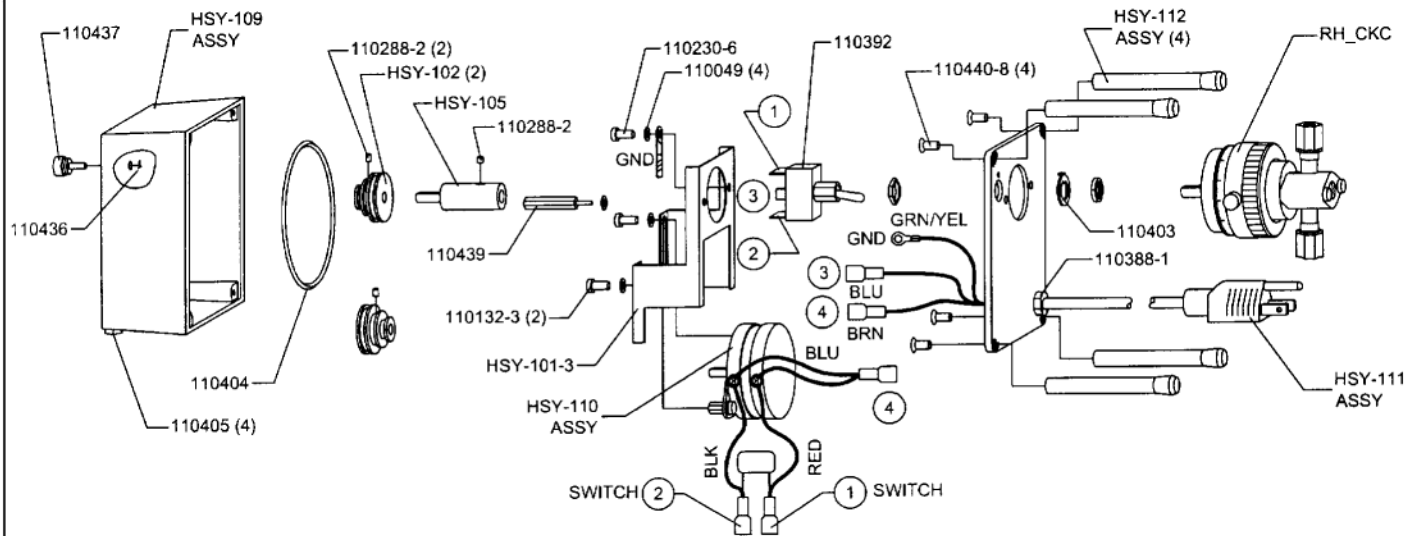

MODELS RHSY0CKC AND RHSY1CKC

FIG7d



# FMI LAB PUMP, MODEL PiP

## PARTS IDENTIFICATION SHEET H431-02

CONGRATULATIONS! THE FMI MICRO  $\pi$ -PETTER "PiP" IS ONE OF THE FINEST VOLUMETRIC DISPENSING SYSTEMS AVAILABLE. IT FEATURES AN FMI LAB PUMP JR., MODEL RH VALVELESS METERING PUMP HEAD, COUPLED TO A SIMPLE, SINGLE REVOLUTION

DRIVE, AND IS ACTUATED BY A PENDANT HAND/FOOT SWITCH. REPEAT ACCURACIES OF 0.5% OR BETTER CAN BE ATTAINED FOR PIPETTING, DISPENSING, OR ANY VOLUMETRIC OPERATIONS WITH THE FMI MICRO  $\pi$ -PETTER.

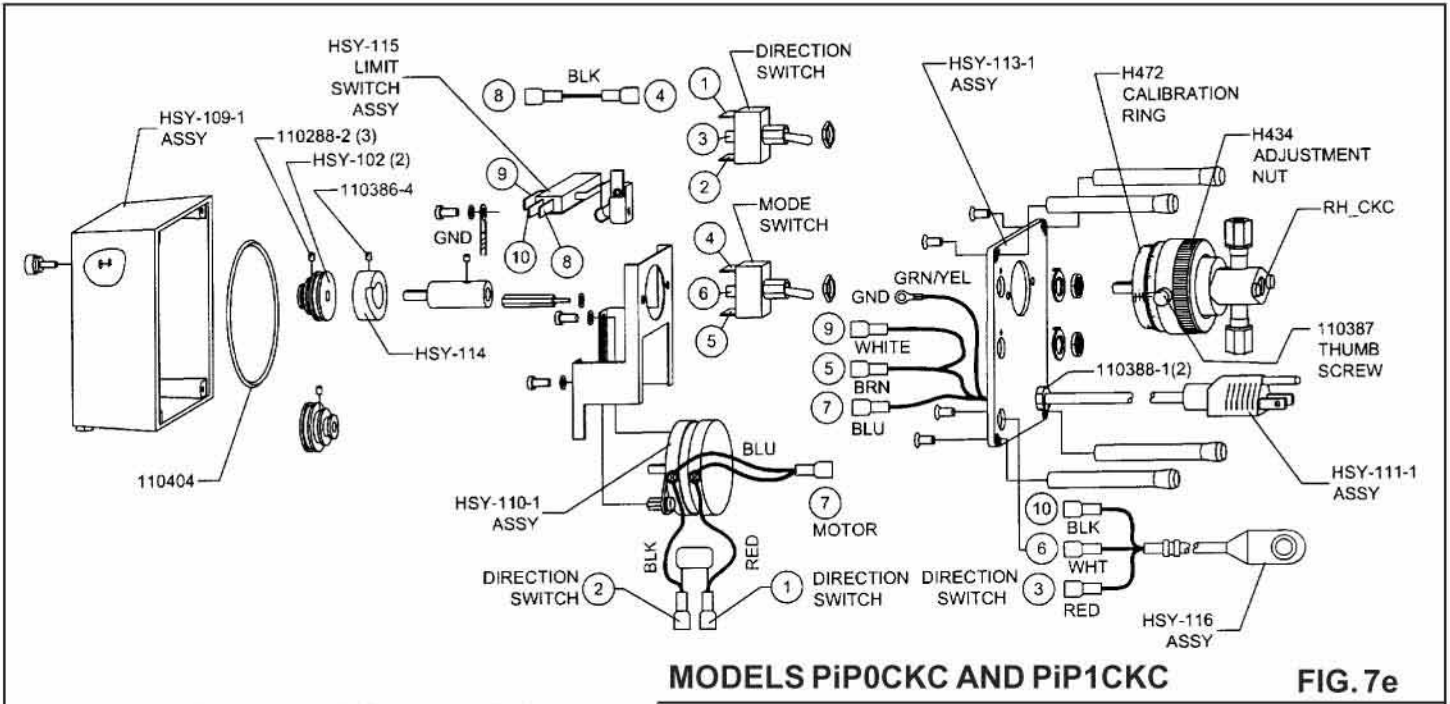

MODELS PiP0CKC AND PiP1CKC FIG. 7e

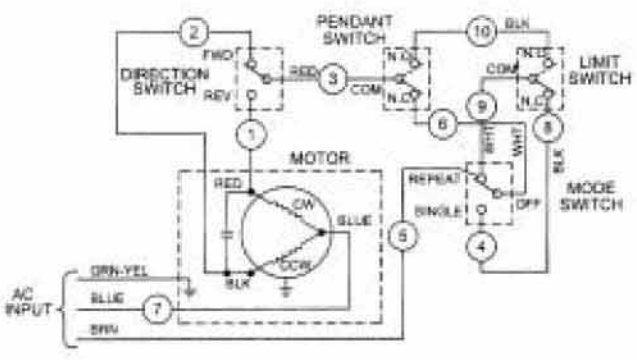

**ELECTRICAL DIAGRAM**  
micro  $\pi$ -petter®

**REPAIR SERVICE**  
Should your FMI PUMP or PUMP SUBASSEMBLY need repairs, you should first contact the Customer Service Department for a Return Authorization Number, you may then ship it to us post-paid. You will be charged a flat \$38,00 service fee for each Pump Head Module and \$38,00 for each Pump Drive Module returned plus the cost of parts used and the postage required to return it to you. The Pump Head Module service fee includes inspection, clean and test to agreed specifications and the replacement of lip seals and gland washer.

If after examining a returned pump or subassembly, the FMI Service Department estimates the total cost to be in excess of \$60.00, you will be requested to approve the charges before repair work is started.

**PARTS ORDERS**  
**MINIMUM ORDER \$25,00 DOMESTIC or FOREIGN** (Invoice price exclusive of shipping charges and any applicable discounts).

**SHIPPING**  
Parts and repair orders will be shipped via United Parcel Service or U.S. Postal Service unless other means are specified.

**PLEASE NOTE**  
PISTON AND CYLINDERS SHOULD BE DIMENSIONALLY MATED AT THE FACTORY. FOR MOST SATISFACTORY PERFORMANCE, THEY SHOULD BE ORDERED AS MATED SETS

## PARTS PRICE LIST - RH PUMP MODELS

PART NO.	DESCRIPTION
H406	GLAND NUT
H408-0A	LIP SEAL, RULON A, 3/16" PISTON (RH0)
H408-1A	LIP SEAL, RULON A, 1/4" PISTON (RH1)
H408-0CJ	LIP SEAL, RULON J, 1/8" PISTON (RH00)
H409-0	GLAND WASHER, TEFLON 3/16" PISTON (RH0)
H409-1	GLAND WASHER, TEFLON 1/4" PISTON (RH1)
H409-00	GLAND WASHER, TEFLON 1/8" PISTON (RH00)
H424	SPINDLE ASSY (RH)
H424-1	SPINDLE ASSY (RHB) (RHV)
H434	ADJUSTMENT NUT WITH DECAL
H435	CYLINDER CAP WITH DECAL
H441	SUPPORT RING
H470	BASE ASSY
H470-1	BASE ASSY (RHB) (RHV)
H472	CALIBRATION RING WITH DECAL
H472-1	CALIBRATION RING WITH DECAL (RHB) (RHV)
H474	ADAPTER PLATE, (MASTERFLEX)
H481-1	BRACKET, ADAPTER (Q)
H482	COUPLING
H482-1	COUPLING, DRIVE - (MASTERFLEX)
H485	BEARING ASSY
H486	CYLINDER SUPPORT ASSY (H470)
H486	CYLINDER SUPPORT ASSY (H470-1)
HSY-101-3	BRACKET-MOTOR DRIVE ASSY
HSY-102	PULLEY
HSY-105	EXTENSION-SHAFT
HSY-109	CASE ASSY (RHSY)
HSY-109-1	CASE ASSY (PIP)
HSY-110-1	MOTOR DRIVE ASSY, 115 VAC 60 HZ
HSY-110-2	MOTOR DRIVE ASSY, 230 VAC 50 HZ
HSY-111	LINE CORD ASSY
HSY-111-1	LINE CORD ASSY (PIP)
HSY-112	FOOT ASSY
HSY-113	COVER ASSY
HSY-113-1	COVER ASSY (PIP)
HSY-114	CAM (PIP)
HSY-115	LIMIT SWITCH ASSY (PIP)
HSY-116	PENDANT SWITCH ASSY (PIP)
HSY-119	JUMPER ASSY (PIP)
HSY-120	PACKING BOX (RHSY) (PIP)
V111	RHV MOTOR ASSY, 90 VOLT

PART NO.	DESCRIPTION
110036	O-RING
110049	WASHER, #8 INT LOCK
110132-3	SCREW, #8-32 x 3/16" PAN HEAD
110132-8	SCREW, #8-32 x 1/2" PAN HEAD
110132-18	SCREW, #8-32 x 1 1/8" PAN HEAD
110132-54	SCREW, #8-32 x 3 3/8" PAN HEAD
110230-6	SCREW, #8-32 x 3/8" PAN HEAD
110288-2	SET SCREW, #8-32 x 1/8" LONG
110288-4	SET SCREW, #8-32 x 1/4" LONG
110301	DRIVE PIN
110366	PISTON DRIVE PIN
110372	RETAINER, SPRING-RING
110384-K	FERRULE NUT, 1/4" O.D.
110384-T	FERRULE NUT, TEFLON
110386-4	SET SCREW, #8-32 x 1/4" LONG-NYLON TIP
110387	THUMB SCREW
110388	BUSHING - STRAIN RELIEF
110388-1	BUSHING - STRAIN RELIEF (PIP)
110392	SWITCH-TOGGLE
110403	LOCK RING (SWITCH)
110404	DRIVE BELT
110411	SPACER, 3/8" x 3/4" LONG
110433	SWITCH - TOGGLE (DIRECTION) (PIP)
110436	EXTERNAL HAIR COTTER PIN
110437	THUMB SCREW, #8-32 x 13/32" LONG
110439	STAND-OFF MALE TO FEMALE, #8-32 x 1 7/8" LG
110440-8	FLAT HEAD SCREWS, 82" #6-32 x 1/2" LONG
110442	WIRE WRAP TIE (PIP)
110655-20	SCREW
110837-01	SPRING & BRUSH SET 12 VDC GRAY
110838-01	SPRING & BRUSH SET 90 VDC GRAY
110839-01	BRUSH CAP 12, 90 VDC GRAY
200103-01	DRIVE ASSY RHB 90 VDC
200103-02	DRIVE ASSY RHV 90 VDC
200113	"H" SPINDLE BEARING
200117	BASE ASSY RH
200174-01	MOTOR ADAPTER KIT
200175-02	MOTOR ASSY, RHB 12 VDC

PART NO.	DESCRIPTION
H430	PACK BOX
H476-K	SMALL TUBE ADAPTER SET 1/8" O.D. (OPTL)
R412-5K	ADAPTER, KYNAR 1/4-28 THD I.D. (OPTL)
RH/M	MASTERFLEX DRIVE ADAPTER KIT
RH/Q	Q MOTOR DRIVE ADAPTER KIT
H-0CKCV	PISTON/CYLINDER GROUP 3/16" DIA.
H-1CKCV	PISTON/CYLINDER GROUP 1/4" DIA.
H-0CKC-LFV	PISTON/CYLINDER GROUP 3/16" DIA. L.F.
H1CKC-LFV	PISTON/CYLINDER GROUP 1/4" DIA. L.F.
H-0CTCV	PISTON/CYLINDER GROUP 3/16" DIA. TEFZEL
H-1CTCV	PISTON/CYLINDER GROUP 1/4" DIA. TEFZEL
H-0CTC-LFV	PISTON/CYLINDER GROUP 3/16" TEFZEL L.F.
H-1CTC-LFV	PISTON/CYLINDER GROUP 1/4" TEFZEL L.F.
H-00SKY	PISTON/CYLINDER GROUP 1/8" S.S.
H-00SKY-LF	PISTON/CYLINDER GROUP 1/8" DIA. S.S.
RH0CKC	LAB PUMP JR. 3/16" DIA. PISTON
RH1CKC	LAB PUMP JR. 1/4" DIA. PISTON
RH0CKC-LF	LAB PUMP JR. 3/16" DIA. PISTON LOW FLOW
RH1CKC-LF	LAB PUMP JR. 1/4" DIA. PISTON LOW FLOW
RH0CTC	LAB PUMP JR. 3/16" DIA. PISTON TEFZEL
RH1CTC	LAB PUMP JR. 1/4" DIA. PISTON TEFZEL
RH0CTC-LF	LAB PUMP JR. 3/16" DIA. PIST. TEFZEL L.F.
RH1CTC-LF	LAB PUMP JR. 1/4" DIA. PIST. TEFZEL L.F.
RH00SKY	LAB PUMP JR. 1/8" DIA. PIST. S.S.
RH00SKY-LF	LAB PUMP JR. 1/8" DIA. PIST. S.S. L.F.
RH00STY	LAB PUMP JR. 1/8" DIA. PIST. TEFZEL
RH00STY-LF	LAB PUMP JR. 1/8" DIA. PIST. TEFZEL L.F.

### IMPORTANT!!

**WHEN ORDERING REPLACEMENT PARTS, PLEASE MENTION MODEL & SERIAL NUMBERS OF PUMP ON WHICH THEY WILL BE USED**

### FMI LAB PUMP, RH MODELS PARTS IDENTIFICATION SHEET H431-02

ALL PRICES ARE QUOTED IN U.S. DOLLARS, F.O.B. SYOSSET, N.Y. SUBJECT TO CHANGE WITHOUT NOTICE, MINIMUM ORDER \$15.00 NET. (INVOICE PRICE EXCLUSIVE OF SHIPPING CHARGES)



# FLUID METERING, INC.

5 AERIAL WAY, SUITE 500, SYOSSET, NY 11791  
(800) 223-3388 • (516) 922-6050 • FAX (516) 624-8261 • <http://www.fmipump.com>



**13. PIP RECALIBRATION.** Turn knurled ADJUSTMENT NUT 2-1/4 turns CCW (225 on scale) from zero displacement position. Clear bubbles from line and pump 20 shots into a calibrated receiver (pipette, burette, graduate). Divide the measured volume by 20 to find the per shot volume, which should be 25  $\mu$ l for the H-0 or 50  $\mu$ l for the H-1. If an error exists repeat the foregoing. If error is confirmed, adjust for error difference (CW for decrease, CCW for increase) using CALIBRATION RING graduations to measure distance to new setting. Repeat test and correction procedure until correct result is achieved. Then, loosen THUMB SCREW on CALIBRATION RING and rotate ring to obtain a reading of 225 when the CALIBRATION RING is aligned with the fixed calibration line on the left side of the pump. Retighten THUMB SCREW. Your pump is now recalibrated for stroke adjustment as per paragraph 12.

**14.** Your micro  $\pi$ -petter® "PiP" is similar in design to a standard FMI RHSY metering pump unit. Please review paragraphs 1 through 8 for details regarding the RH pump head and the RHSY drive system.

**15. CAM ADJUSTMENT.** Your micro  $\pi$ -petter® PENDANT SWITCH relates directly to a CAM HSY-114 actuated LIMIT SWITCH ASSEMBLY HSY-115 which is timed to the RH piston suction position; to adjust this CAM, **unplug power cord**, loosen THUMB SCREW on rear of CASE ASSEMBLY HSY-109-1 and remove CASE ASSEMBLY. The CAM timing and height are adjusted by one SET SCREW 110386-4 (see fig. 4). Align SET SCREW in CAM to index line on EXTENSION SHAFT HSY-105. Lower CAM until recessed surface of CAM contacts LIMIT SWITCH ASSEMBLY HSY-115. Tighten set screw. Check for 2 SWITCH "clicks" per revolution. **REPLACE CASE ASSEMBLY** before plugging electric cord into outlet.

**16. NOISE AT HIGH PUMP RATES.** A metallic hammering noise during operation of your pump (particularly high speed units such as RHB and RHV) when pumping liquids indicates presence of gas bubbles in the pumping chamber which are reducing pumping capacity and may be damaging cylinder walls. Such bubbles may be traced to 1) a poor seal at the suction fitting, 2) fluid vaporization (cavitation) or, 3) degassing of the fluid.

a) To eliminate vaporization and degassing noise, reduce suction load. This may be accomplished by: 1) Increase in suction line inside diameter; 2) reduction of suction supply height; 3) pressurization of suction supply container; 4) locating pump below supply source to permit gravity flow aid; 5) reduce viscosity of fluid by heating or thinning; 6) reduce flow rate by adjusting pump to lower setting on flow scale; 7) install FMI PD-HF PULSE SUPPRESSORS in suction and discharge lines. We hear of good results in noise abatement and pump life extension from folks who put pulse suppression hardware in their plumbing circuits

adjacent to the pump suction and discharge ports - particularly with high speed pumps, RHB and RHV, that are plumbed with rigid tubing. Theory holds that if part of a generated pulse is resiliently stored, the part not stored is smaller and thus easier to get in motion; the stored part of the pulse dissipating behind the part that is in motion sustains motion, causing an undulating flow to be transmitted rather than a series of pulses. Results; less noise, less energy used and less agitation of the pumped fluid. So for pulse noise and vibration problems, put a little resilience in your circuit. There are a number of easy ways to do it.

b) The simplest method is to use resilient tubing between the pump and the fluid circuit. Experiment a bit with standard elastomers - viton, hypalon, gum rubber, soft vinyl or other. Use only unreinforced tubing (reinforcement takes away the resilience).

**Always shield this type of arrangement** so that a possible tube rupture will not endanger people or equipment.

c) Another popular pulse suppression arrangement involves a gas bubble trap. A bubble in such a vertical trap will suppress pulse shock and noise temporarily. However, since gas and a liquid in contact under agitated conditions seldom stabilize, the trapped gas may be absorbed into the passing liquid and disappear leaving no pulse suppression or the fluid may contribute to the gas quantity, overload the trap and cause random pumping errors as occasional bubbles enter the flow stream. This can be overcome by fitting a soft slug of closed-cell plastic foam or a soft pillow of thin-wall plastic tubing (ends sealed) into the vertical dead end extension of the fluid line. The gas trapped in the foam or pillow will provide the required resilience but will not be absorbed by the flow stream.

d) Since each fluid and circuit exhibits a differing characteristic, a bit of experimentation may be necessary. The results are usually worth the effort.

**17. FOR BEST LOW FLOW PUMPING RESULTS:** Use a pump having maximum flow rating as near to the desired flow rate as possible and keep suction and discharge pressures essentially constant (see para 19). You may obtain fine results with the new FMI RH-LF Pump Head fitted with Q661 a Small Bore Tubing Kit. And, to assure continuous good results, beware of bubbles! (see para 18)

**18. LOW FLOW BUBBLE PROBLEMS.** A common cause of trouble in metering pump applications requiring low flow rates - a few milliliters per minute or less - is the seemingly inevitable gas bubble trapped in the pumping head of the metering pump. It expands on the suction stroke and contracts on the discharge stroke, allowing little, if any, liquid

to pass through the pump. Such bubbles, though often attributed to leaks in pump seals, can usually be traced to gases released by the pumped fluid in response to pumping agitation or pressure/temperature changes. When so identified, this potential source of metering pump error can be effectively controlled in most fluid circuits.

The familiar bubbles that form on the inside walls of a tumbler of tap water after it stands for a period of time at room temperature demonstrate the typical liquid degassing that results from pressure reduction (water line pressure to atmospheric) and/or temperature elevation (from ground ambient to air ambient). In this case, the bubbles contain air, hydrogen, carbon dioxide or other gaseous materials carried in the water, only small quantities of vaporized water are present. Some liquids respond to agitation and/or pressure/temperature changes by chemically separating into liquid and gas fractions; others simply vaporize, physically changing from liquid to gaseous form. Examples of liquids releasing gas or changing from liquid to gaseous form in response to agitation and temperature/pressure changes are numerous in the modern technical environment and many techniques have been devised to compensate for or correct their presence.

The most common practices for bubble control employ:

a) pressure on the suction side of the pump circuit to encourage gas retention in the liquid or,

b) employ natural buoyancy of the bubbles to carry them away from or through the pump head.

To apply pressure on the suction side of the pump, locate the pump physically below the supply vessel. Each two feet of elevation difference represents pressure of approximately one pound per square inch (psi). Bubbles that do occur will return to the supply vessel by buoyant lift. This is called a positive suction or flooded suction arrangement.

If it is necessary to draw liquid up from the supply vessel to the pump head, negative suction pressure must be contemplated - again, approximately 1 psi per two feet of lift. Most liquids will release some gas when held at negative pressure and since the volume of gas released is generally proportionate to the volume of liquid subjected to the negative pressure, suction line diameter should be kept small for small flows (except heavy, viscous or tacky liquids which require large flow area for mobility). A vertical dead-end extension of the suction line can be provided above the pump suction port to trap line-generated bubbles before they enter the pump. This extension should be liquid filled at the start of a pumping period.

Hanging the pump vertically with motor at 12 noon and pump head at 6 pm will allow bubbles that enter the pump head to pass directly through with buoyant assist. Discharge lines should be inclined upward from pump head and bubble traps should be purged as often as necessary to assure liquid flow continuity.

**19. SYSTEM PRECISION FACTORS.** Several interrelated factors are involved in the exceptional operating precision possible in systems using FMI LAB PUMPS. Of primary concern are the following:

a) FMI LAB PUMP DISPLACEMENT precision is based on a simplified positive stroke mechanism which has no secondary linkages to produce stroke to stroke mechanical errors and has no gravity actuated or spring loaded valves to introduce random valve seating errors. The single mechanical linkage components between the LAB PUMP piston and its drive elements is a precision spherical bearing which transforms circular drive motion into elliptical thrust motion (reciprocation). The total mechanical clearance of this linkage is less than 0.1 of the maximum pump stroke length or, approximately 0.0003". Thus it may be said that LAB PUMP displacement precision (stroke to stroke) is in the order of the mechanical linkage clearance; that is to say, stroke to stroke displacement is reproducible to less than 0.5 within the rated capacity of a given pump model.

b) FMI LAB PUMP VALVING is performed by a slot in the piston which is mechanically aligned with one cylinder port during the suction portion of each stroke and with the other cylinder port during the discharge portion of each stroke. The slot alignment is controlled by the single drive bearing discussed in the preceding sentences. The valve action is therefore mechanically precise, and free of random closure variations.

c) FLUID SLIP, a term commonly used to describe the migration of fluid around the internal moving parts of gear, lobe and vane pumps, is the volumetric difference between physical component displacement and fluid through-put of a pump system. In the FMI LAB PUMP, slip loss refers to the fluid which passes through the clearance space (approx. .0002") between the piston and the cylinder wall. Since this clearance represents a restrictive passage of essentially constant dimension, it will be readily seen that the slip rate is determined by viscosity, pressure and time: e.g. assuming constant fluid viscosity and pressure, slip will be a smaller factor in a high repetition rate pump (short time per stroke) than in a low repetition rate pump. As viscosity increases and pressure decreases, time (or repetition rate) becomes less a significant contributor to slip loss.

d) STROKE REPETITION RATE is directly related to drive motor speed which in turn is influenced by work load and electrical sup-

ply voltage, i.e. motor speed decreases when work load increases and when electrical supply voltage (115 Volts AC) decreases. This motor speed variation may amount to as much as 15 for work load variations between zero discharge pressure and maximum rated discharge pressure. A 10 voltage drop may result in as much as 20 motor speed reduction when the pump is operating against a significant head pressure.

e) THE FLOW STABILITY (precision) of an FMI LAB PUMP is therefore principally related to consistency in fluid slip rate and stroke repetition rate and these functions in turn are related to external system load factors such as viscosity, differential pressure and electric line voltage; i.e., when load factors remain essentially constant, slip rate and repetition rate remain essentially constant; when viscosity increases, fluid slip rate and stroke repetition rate both decrease; when differential pressure increases fluid slip rate increases and stroke repetition rate decreases.

In short, FMI LAB PUMP PRECISION is influenced by fluctuations of fluid differential pressures, fluid viscosity and electric line voltage. When these factors are controlled predictably reproducible pumping precision better than 0.5 may be expected.

## MAINTENANCE & REPAIR INSTRUCTIONS

**20. REMOVING PISTON/CYLINDER GROUP ASSEMBLY.** (refer, Fig 8.) remove two 110655-20 screws and while holding cylinder ports in place, slip part H435 off of CYLINDER ASSEMBLY H422. Tilt the assembly

as shown in **figure 8**. This will permit removal of PISTON DRIVE PIN 110366 from SPHERICAL BEARING H477 **without fully withdrawing piston from liner.**

**21. SERVICING OF PISTON/CYLINDER GROUP ASSEMBLY.** If teardown for detail cleaning or seal replacement is required, remove parts with care to avoid damage to piston, cylinder and seals. For piston/cylinder sets with scavenger slots. Carefully remove all solid matter that may have collected in the scavenger slot - the groove inside the cylinder liner that extends from the left hand port to the seal reservoir. This tiny groove serves the dual purposes of minimizing seal wear and seal weepage by maintaining near atmospheric pressure on the inside seal surfaces. **KEEP IT CLEAN!** Wipe all parts with lintless oil-saturated cloth. The H408 SEALS that keep your LAB PUMP piston dry are not "just ordinary plastic discs." They are precisely cut and formed from sheets of chemically inert fluorocarbon, specifically formulated for resistance to wear, abrasion, heat and chemical attack.

Each H408 SEAL possesses an exceptional mechanical memory which allows it to maintain a relatively constant wiping pressure on the piston, compensating for seal wear as it occurs. Properly maintained in cleaned condition, the original SEALS on an FMI LAB PUMP may be expected to last the life of the pump. If they are removed for any reason, they should be carefully cleansed of all foreign particles prior to reassembly. Seal seats must also be free of particles.

When H408 SEALS are replaced, the following procedure should be followed: (please see fig. 7a)

## IMPORTANT

**RECOMMENDED FMI PUMP MOUNTING FOR MAXIMUM PERFORMANCE**

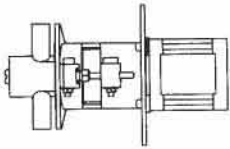

**GOOD**

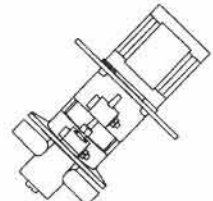

**BETTER**

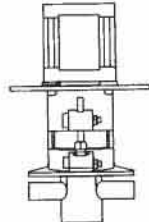

**BEST**



**NOT RECOMMENDED**

For maximum pump performance, mount the pump with motor at 12 o'clock and pump head at 6 o'clock position. This orientation will allow air bubbles that enter the pumping chamber to directly exit thru buoyant assist. Discharge lines should be inclined upward from pump head.



**FLUID METERING, INC.**

5 AERIAL WAY, SUITE 500, SYOSSET, NY 11791

(516) 333-3338 • (516) 333-3333 • FAX: (516) 334-8267 • <http://www.fluidpump.com>



**FIG. 3**

- Place GLAND NUT H406 and GLAND WASHER H409 on PISTON ASSEMBLY H423.
- First "form" lip of LIP SEAL around piston by gently placing a LIP SEAL H408 on piston, **lip side last**. Carefully rotate the seal on the piston to avoid damage to the lip while passing over the flat to the piston neck. Then remove seal and reverse lip direction.
- Gently place one "formed LIP SEAL H408 on piston, **lip side first**, carefully rotating the seal on the piston until it is past the flat and on the piston neck.
- Gently place two LIP SEALS H408 on piston, **lip side last**. Carefully rotate the seals on the piston to avoid damage to the lip while passing over the flat to the piston neck.
- Insert piston into CYLINDER ASS'Y H422 and tighten GLAND NUT H406.
- Rotate piston by hand after reassembly to assure free movement in cylinders and seals.

**22. PISTON/CYLINDER GROUP ASSEMBLY REPLACEMENT.** (refer, figs. 8 & 9) Install "O" RING 110036 over GLAND NUT H406. Note in fig. 8 that PISTON DRIVE PIN 110366 must be guided into SPHERICAL BEARING H477-1 while the piston and cylinder remain assembled. This for the purpose of avoiding assembly damage to the seals. When PIN is in bearing, seat GLAND NUT with "O" RING in SUPPORT H433 as shown in fig. 9. **OPERATE PUMP MANUALLY FOR SEVERAL STROKES BEFORE APPLYING POWER.**

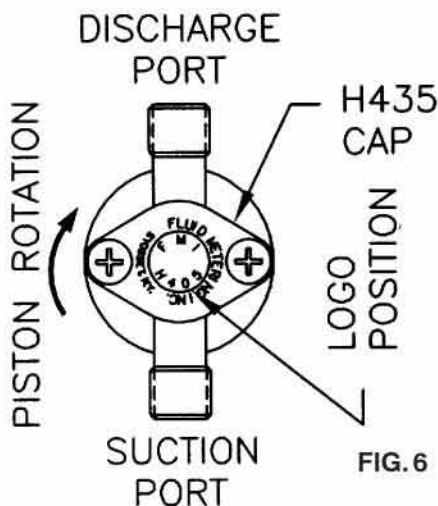

FIG. 6

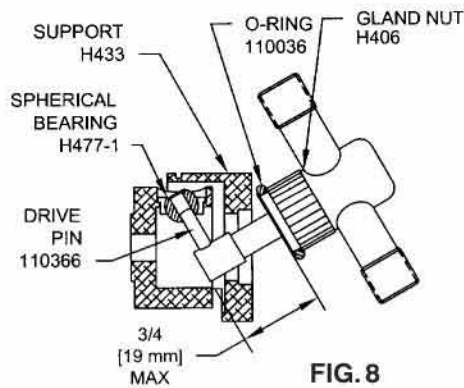

FIG. 8

NOTE THAT PISTON IS VISIBLE IMMEDIATELY BEHIND "LOGO" DURING AT LEAST PART OF EACH REVOLUTION OF PUMP SHAFT - WITHOUT ACTUALLY CONTACTING BACK OF "LOGO"

**23. ADJUSTING PISTON/CYLINDER RELATIONSHIP.** (refer, figs. 7a, b) If piston is not visible behind "LOGO" or if it contacts "LOGO" during operation, H485 BEARING ASSEMBLY should be adjusted. This situation may occur when PISTON ASSEMBLY H423 has been replaced. To make this correction (see fig. 7a).

- Loosen THUMB SCREW 110387 and remove CALIBRATION RING H472 then loosen SET SCREW 110288-2 in BASE ASSEMBLY H470.
- Turn BEARING ASSEMBLY H485 with FMI supplied spanner wrench counterclockwise 1 full turn.
- Turn ADJUSTMENT NUT H434 clockwise until its threads are completely seated on BASE H432.
- Rotate BEARING ASS'Y H485 clockwise until PISTON ASS'Y H423 just touches back of logo (as described above) when rotated 360°.
- Once properly adjusted rotate H485 counterclockwise 1/4 turn and tighten SET SCREW 110288-2. Replace CALIBRATION RING H472.
- Turn ADJUSTMENT NUT back to its normal operating range and run pump.

**23.1 RHB & RHV PISTON/CYLINDER RELATIONSHIP.** To correct piston position on RHB & RHV pumps:

- Loosen THUMB SCREW 110387 on CALIBRATION RING H472-1, rotate until 1/4" hole lines up with piston adjustment hole on BASE H432-1 (fig. 7b).
- Looking into piston adjustment hole, rotate motor shaft until SET SCREW 110386-4 is visible, loosen set screw.
- Turn ADJUSTMENT NUT H434 clockwise until threads are completely seated on BASE H432-1.
- Position SPINDLE H424-1 forward until PISTON ASS'Y H423 is visible at back of logo as described above. Tighten set screw.
- Check for smooth shaft rotation by turning motor shaft by hand. Repeat step (d) if required. To recalibrate see sec. 12.

**24. PISTON SEAL SETTING.** After installing new LIP SEALS H408 in pump head it is recommended that the SEALS be set (formed in place) by fluid pressures generated by pump action. To accomplish this:

- Operate the pump spindle clockwise for 10 or 20 strokes at maximum setting, handling water (left to right mode facing the pump head with suction line blocked or pinched off). This will create a vacuum in the pump head, permitting atmospheric pressure to shape the outer seal member tightly around the piston.
- Reverse the pumping direction (spindle direction reversed "CCW" on RH pumps) and partially block the suction line. This will generate pressure in the seal area of the pump head, causing the inner seals to form intimately around the piston.

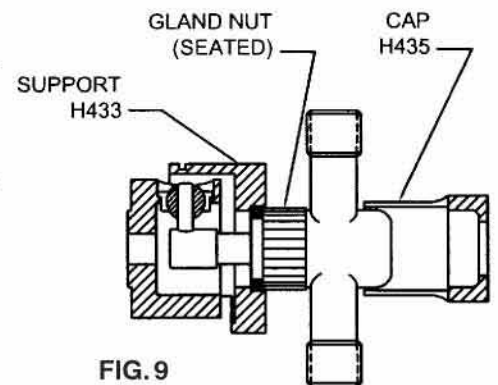

FIG. 9